

# INSTRUCTIONS FOR THE HAFLER DH-202 AMPLIFIER BRIDGING KIT FOR THE DH-200

The DH-202 Amplifier Bridging Kit for the DH-200 consists of a PC-7A circuit board comprising a 6 transistor phase inverting amplifier, a mounting bracket, necessary hardware and connecting wire. Installation may take about an hour. All changes to the amplifier wiring are performed on the right channel - the side nearest the power switch. Only the left channel input will be utilized after conversion so an additional pair of input wires will be connected to that jack to enable it to feed the complete amplifier.

When converted to monophonic operation, the loudspeaker load is to be connected to the two center red (+) outputs only. The right (+) will act as the common and should be attached to the speaker (-). This is what is known as a floating output, for no connection is made to either black ground terminal. It is suggested that once the amplifier has been converted, some clear

indication be made as to the appropriate connections, and that be attached to the back panel. Because of this floating output, neither side of the output signal may be grounded; such as thru a speaker switching box or head phone adapter that has a common ground between the left and right channels.

For equivalent load impedances, the speaker fuses provide the same power output protection as in stereo operation, but because of individual fuse variations, only one fuse may blow at these levels. It is best to replace both fuses if one blows, as the other may have been weakened.

These installation instructions designate connections in accordance with the DH-200 owner's manual and pictorial diagram, and use the same terminology (i.e. "S" indicates a soldered connection).

## KIT PARTS LIST

1	PC-7 Board	WP-PC7
1	Mounting bracket	SM-BRT202*
2	Screw, Machine, 6-32 x 1/2"	HWH-172
2	Screw, Machine, 4-40 x 5/16"	HWH-145
2	Nut, 6-32 KEP	HWH-117
2	Nut, 4-40 KEP	HWH-105
1	Wire, Red #20 GA	3.0'
1	Wire, Green #20 GA	3.0'
1	Warranty Card	LIT-WAR

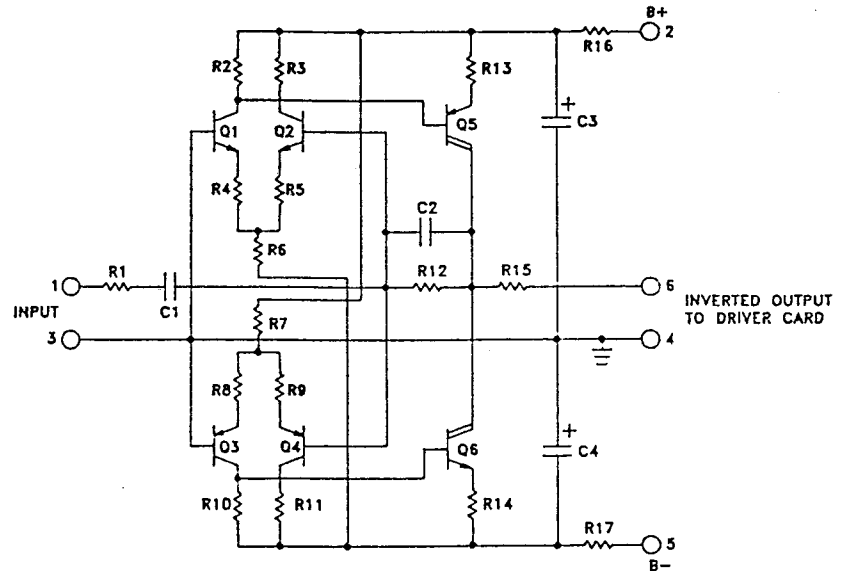

## LIMITED WARRANTY

The parts in the DH-202 are warranted for a full year from the purchase date including parts and labor. If a defective component is found on a circuit board or in the kit, simply return the individual part, or if the problem is unknown, return the defective board to the factory, prepaid, together with the serial number and a copy of the dated bill of sale, and it will be repaired or replaced at no charge. This warranty is limited to repair or replacement of the DH-202 bridging module only. Hafler is not responsible for consequential damages. This warranty gives you specific legal rights. You may also have other rights which vary from state to state.

This warranty is void if acid core solder or paste flux has been used.

# Hafler

A Division Of Rockford Corporation  
613 S. Rockford Drive, Tempe, Arizona 85281 • (602) 967-3565

# DH-202 INSTALLATION INSTRUCTIONS

1.  Disconnect AC power from the DH-200 and remove all connecting cables.
2.  Remove 4 screws from the upper portion of the left output module, and all of the 8 screws attaching the right output module (the one near the power switch). Remove the amplifier cover, and tilt the right module outwards for easier access.
3.  Disconnect the pair of twisted wires connected to the right input socket RS. The resistor may be left connected if you wish, but this input will not now be used. Unsolder this twisted pair from eyelets 1 and 2 at the top of the PC-6 output module. The reason these wires will not simply be reconnected to PC-7A is that they may be too heavy a gauge to fit into the eyelets on the new board.
4.  Prepare one each red and green wires of the following lengths: 6-1/2", 10", and 11". Twist them together in pairs of equal lengths.
5.  Select the longest red/green pair and slip it under all of the wires attached to the back panel between the two input sockets. Connect the green wire to the ground lug #1 of the left socket LS. (S-2). Connect the red wire to lug #2. (S-2).
6.  Select the shorter red/green pair and place it between the two fuses FR near the center of the chassis alongside the transformer. Connect the green wire to lug #2, which is closest to the center of the transformer. (S-2). Connect the red wire to lug #4 beside it. (S-2).
7.  Select the two larger screws and nuts, and mount the bracket on the rear fin of the right heat sink between the two transistors, with the bracket bends next to the fins.
8.  With the smaller bolts, fasten the circuit board on the outside of the bracket, with the components toward the rear of the amplifier.
9.  Using the remaining red/green pair, connect one green end to eyelet #2 at the top towards the front of the PC-6 module. (S). Connect the adjacent red wire to eyelet #1. (S). At the other end, connect the green wire to eyelet #4 on the components side of PC-7A. (S). The #1 eyelet is at the top of the PC-7A board. Connect the red wire to eyelet #6. (S).
10.  Select the shorter pair, which is connected to the fuses. Connect the other end of the green wire to PC-7A eyelet #5. (S). Connect the red wire to eyelet #2. (S).
11.  With the remaining pair from the left input socket, connect the green wire to eyelet #3. (S). Connect the red wire to eyelet #1. (S).
12.  Secure the output module to the chassis with 4 screws. You may wish to leave them loose until the cover is installed. With the module in position, place the input pair about 1/2" out from the PC-6 board, straight down to the chassis, across the chassis and underneath PC-7A. The pair from the fuses should likewise be against the chassis, and in general all wires to those fuses should be kept away from the PC-6 circuit board.
13.  Install the cover and the remaining screws.

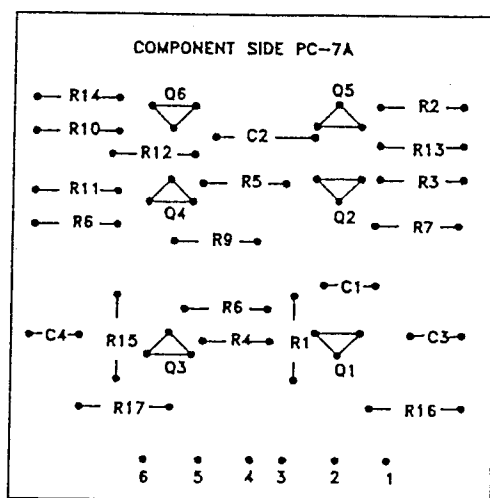

## PC-7A PARTS LIST

R1	22.1K, 1%, metal film	RMP/4-2212
R2	2.2K, 1/4w, 5% carbon film	RC/4-222
R3	2.2K, 1/4w, 5% carbon film	RC/4-222
R4	47 ohms, 1/4w, 5% carbon film	RC/4-470
R5	47 ohms, 1/4w, 5% carbon film	RC/4-470
R6	8.2K, 1/4w, 5%, carbon film	RC/2-822
R7	8.2K, 1/4w, 5%, carbon film	RC/2-822
R8	47 ohms, 1/4w, 5% carbon film	RC/4-770
R9	47 ohms, 1/4w, 5% carbon film	RC/4-770
R10	2.2K, 1/4w, 5% carbon film	RC/4-222
R11	2.2K, 1/4w, 5% carbon film	RC/4-222
R12	22.1K, 1%, metal film	RMP/4-2212
R13	100 ohms, 1/4w, 5% carbon film	RC/4-101
R14	100 ohms, 1/4w, 5% carbon film	RC/4-101
R15	47 ohms, 1/4w, 5% carbon film	RC/4-770
R16	3.3K, 1w, 5%, metal film	RM1-332
R17	3.3K, 1w, 5%, metal film	RM1-332
C1	10mF, 16V, non-polarized	CERNP-106
C2	6.8pF, 100V, dipped mica	CM-068
C3	22mF, 25V, electrolytic	CER-226AA
C4	22mF, 25V, electrolytic	CER-226AA
Q1	BC550C NPN transistor	SSH-650
Q2	BC550C NPN transistor	SSH-650
Q3	BC560C PNP transistor	SSH-651
Q4	BC560C PNP transistor	SSH-651
Q5	MPSA63 PNP transistor	SSH-695
Q6	MPSA13 NPN transistor	SSH-645